

製品仕様書

製品名 : 太陽電池モジュール

型 式 : PVM S200R2

2013. 05. 08.

1. 型名 : PVM S200R2

2. 種類 : 単結晶 太陽電池 (Mono-Crystalline PV Module)

3. 太陽電池モジュール規格

項目	特性	公差
開放電圧(V)	45.63	±3%
短絡電流(A)	5.83	±3%
最大出力電圧(V)	36.74	±3%
最大出力電流(A)	5.46	±3%
最大出力(W)	200	+3%
モジュール効率(%)	16.25	
寸法(mm)	1574 × 782 × 40	
重量(kg)	15.5	

*試験条件 : 1000W/m², 25°C, A.M 1.5

4. 構造及び性能

1) 一般事項

- 使用温度許容範囲
- 周囲温度 : -25 ~ 80°C
- 素子温度 : -40 ~ 90°C

2) 太陽電池単位Cell

- 結晶形態 : 単結晶 Cell
- 寸法 : 125mm × 125mm ±0.5mm
- 厚み : 190μm ±20μm
- ドーピング形態 : P極にN極 ドーピング

- +電極：裏面
- -電極：表面(太陽光受光面)

3) 太陽電池の単位Cell間接続

- 単位電池の数及び接続：72個直列接続
- 接続材料及び方法：Cu フラットケーブル, ろう付け

4) 太陽電池板の重要材料及び断面構造

A. 重要材料

- ① 充填材：EVA(Ethylene Vinyl Acetate)
 - ② 背面材(絶縁材)：PVF/PET/PVF
 - ③ 前面ガラス：低鉄分(Fe) Mist 強化ガラス
鉄分が少ないほど光の透過が良く、ガラスの表面にエンボス(Embossing) 処理をして、光を散乱させることで採光度を向上させる手段としてMistガラスを使うこと。
 - ④ フレーム：アルミニウム(Al-anodized),
- 硫酸表皮処理の後、酸化被膜処理をして腐食防止
 - ⑤ 端子部分
 - 形式：ダイオード内蔵形, 防水形
 - 材質：ABS 成型物
 - 連結リード線：コネクタ ケーブル (90cm)、MC4互換
 - ダイオード：600V 12A *注1 Hot Spot Effect防止用 バイパスダイオード3個
- *注1：太陽電池板の一部分に陰が映る場合は逆起電力が発生され、出力が下がる現象

B. 断面構造

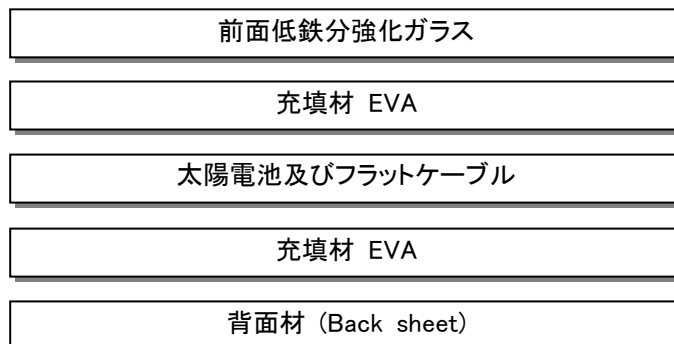

C. 図面

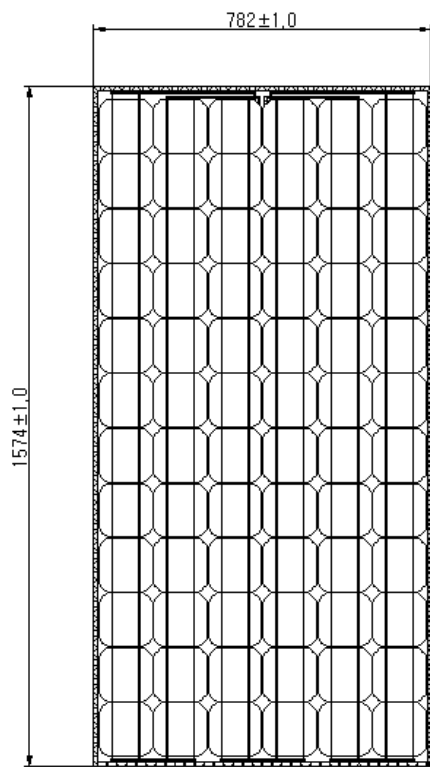

Front View

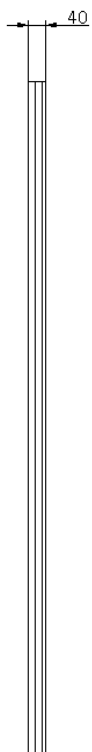

Side View

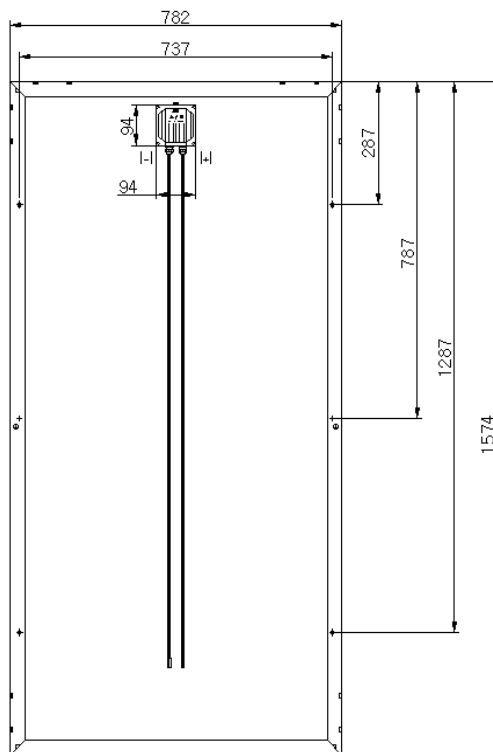

Rear View

E. 梱包

PACKAGING APPROVAL SPECIFICATION DATA SHEET

제품 사진	INTERIOR DESIGN DIGITAL PHOTO	PACKAGING INFORMATION																																														
<table border="1" style="width: 100%; font-size: small;"> <tr> <th colspan="3">DIMENSIONS (mm)</th> <th>WEIGHT PER PIECE (KG)</th> </tr> <tr> <th>L</th> <th>W</th> <th>H</th> <th></th> </tr> <tr> <td>1574</td> <td>782</td> <td>40</td> <td>15.5</td> </tr> </table>	DIMENSIONS (mm)			WEIGHT PER PIECE (KG)	L	W	H		1574	782	40	15.5		PACKAGING METHOD <input checked="" type="checkbox"/> EXPENDABLE <input type="checkbox"/> RETURNABLE <input type="checkbox"/> BACK UP PACKAGING <input type="checkbox"/> OTHER		PALLET TYPE <input type="checkbox"/> BEAT-TREATED <input type="checkbox"/> PLASTIC <input checked="" type="checkbox"/> 2-WAY <input checked="" type="checkbox"/> 4-WAY		SHIPPING TYPE <input type="checkbox"/> SINGLE MODULAR CARTON <input type="checkbox"/> CARTONS ON PALLET (COP) <input checked="" type="checkbox"/> UNIT LOAD (PALLET BOX TYPE) <input type="checkbox"/> OTHER		FREIGHT <input type="checkbox"/> FOB USER <input type="checkbox"/> FOB SUPPLIER <input type="checkbox"/> EX-WORKS <input type="checkbox"/> HS CODE																												
	DIMENSIONS (mm)			WEIGHT PER PIECE (KG)																																												
L	W	H																																														
1574	782	40	15.5																																													
포장 사진 	LIST OF PACKAGING MATERIALS <table border="1" style="width: 100%; font-size: x-small;"> <thead> <tr> <th colspan="6">COMPONENTS</th> </tr> <tr> <th>NO</th> <th>NAME</th> <th>MATERIALS</th> <th>DIMENSIONS (mm)</th> <th># OF PCS.</th> <th>WEIGHT (KG)</th> </tr> </thead> <tbody> <tr> <td>1</td> <td>SLEEVE</td> <td>8506</td> <td>1610*815*910</td> <td>1</td> <td>8.000</td> </tr> <tr> <td>2</td> <td>STC-CAP</td> <td>DW300</td> <td>1630*835*100</td> <td>2</td> <td>3.200</td> </tr> <tr> <td>3</td> <td>Corner Cap</td> <td>SW</td> <td>110*110</td> <td>80</td> <td>0.01</td> </tr> <tr> <td>4</td> <td>Inner Box</td> <td>SW</td> <td>1600*805*92</td> <td>10</td> <td>1.5</td> </tr> <tr> <td>5</td> <td>PALLET</td> <td>WOODEN</td> <td>1640*850*150</td> <td>1</td> <td>12</td> </tr> </tbody> </table>						COMPONENTS						NO	NAME	MATERIALS	DIMENSIONS (mm)	# OF PCS.	WEIGHT (KG)	1	SLEEVE	8506	1610*815*910	1	8.000	2	STC-CAP	DW300	1630*835*100	2	3.200	3	Corner Cap	SW	110*110	80	0.01	4	Inner Box	SW	1600*805*92	10	1.5	5	PALLET	WOODEN	1640*850*150	1	12
COMPONENTS																																																
NO	NAME	MATERIALS	DIMENSIONS (mm)	# OF PCS.	WEIGHT (KG)																																											
1	SLEEVE	8506	1610*815*910	1	8.000																																											
2	STC-CAP	DW300	1630*835*100	2	3.200																																											
3	Corner Cap	SW	110*110	80	0.01																																											
4	Inner Box	SW	1600*805*92	10	1.5																																											
5	PALLET	WOODEN	1640*850*150	1	12																																											
포장 재질 <input type="checkbox"/> SINGLE WALL <input checked="" type="checkbox"/> DOUBLE WALL <input type="checkbox"/> TRIPLE WALL <input type="checkbox"/> WOODEN PALLET <input type="checkbox"/> WOODEN BOX <input type="checkbox"/> LUX PALLET	QUANTITIES <table border="1" style="width: 100%; font-size: x-small;"> <tr> <td>PARTS PER CARTON</td> <td>20</td> </tr> <tr> <td>CARTONS PER SKID</td> <td>8</td> </tr> <tr> <td>PARTS PER SKID</td> <td></td> </tr> </table>						PARTS PER CARTON	20	CARTONS PER SKID	8	PARTS PER SKID																																					
PARTS PER CARTON	20																																															
CARTONS PER SKID	8																																															
PARTS PER SKID																																																
SHIPPING UNIT DIGITAL PHOTO (OR SKETCH) 	WEIGHTS <table border="1" style="width: 100%; font-size: x-small;"> <tr> <td>BOX WEIGHT</td> <td>30.2</td> <td>KG</td> </tr> <tr> <td>TARE SKID</td> <td></td> <td>KG</td> </tr> <tr> <td>PARTS</td> <td>310</td> <td>KG</td> </tr> <tr> <td>GROSS SKID</td> <td>352</td> <td>KG</td> </tr> </table>						BOX WEIGHT	30.2	KG	TARE SKID		KG	PARTS	310	KG	GROSS SKID	352	KG																														
BOX WEIGHT	30.2	KG																																														
TARE SKID		KG																																														
PARTS	310	KG																																														
GROSS SKID	352	KG																																														
	RUST PREVENTION (IF APPLICABLE) <input type="checkbox"/> OILING <input type="checkbox"/> VAPOR CORROSION INHIBITOR (VCI) PAPER <input type="checkbox"/> SILICA-GEL (DESICCANT)																																															
	SKID INFORMATION <table border="1" style="width: 100%; font-size: x-small;"> <thead> <tr> <th rowspan="2"></th> <th colspan="3">OUTSIDE DIMENSIONS (mm)</th> </tr> <tr> <th>L</th> <th>W</th> <th>H</th> </tr> </thead> <tbody> <tr> <td>INSIDE CARTON</td> <td>1610</td> <td>815</td> <td>910</td> </tr> <tr> <td>OUTSIDE CARTON</td> <td>1636</td> <td>841</td> <td>1100</td> </tr> </tbody> </table>							OUTSIDE DIMENSIONS (mm)			L	W	H	INSIDE CARTON	1610	815	910	OUTSIDE CARTON	1636	841	1100																											
	OUTSIDE DIMENSIONS (mm)																																															
	L	W	H																																													
INSIDE CARTON	1610	815	910																																													
OUTSIDE CARTON	1636	841	1100																																													
	STACKING AND LABEL INFORMATION <input checked="" type="checkbox"/> STACK 2 HIGH <input type="checkbox"/> STACK 3 HIGH <input type="checkbox"/> DO NOT STACK <input type="checkbox"/> NOT SPECIFIED																																															
	DOX Compressive STRENGTH INFORMATION (1/3 단위 표) <input type="checkbox"/> 400KG <input checked="" type="checkbox"/> 900KG <input type="checkbox"/> 1000KG <input type="checkbox"/> 1200KG <input type="checkbox"/> 1400KG <input type="checkbox"/> 1500KG																																															
	BOX TYPE GRADE LENGTH WIDTH HEIGHT SILV 800 1636 841 1100																																															
SUPPLIER INFORMATION NAME: Te-Wall KOREA CO.,LTD SUPPLIER ADDRESS: 경남 김해시 주촌면 방막리 291-4 EMAIL: donseol@te-wall.co.kr PHONE: 055-338-1161 FAX: 055-338-1144 HP: 010-2659-8500		USER INFORMATION AND PACKAGING NAME: LS 신전 TITLE: PACKAGING DATE: 2012-12-05		NOTES SUPPLIER: * 본 DATA 수치는 온도28℃, 습도 50% 일 경우의 기준임. 6월 포장자랑																																												
CARTONS PER SKID:																																																